

## RM6-1.3

### Technical Specifications

Nominal Voltage	6V
Nominal Capacity	1.3AH(20HR)
Dimension	
Length	3.82inches(97mm)
Width	0.94inches(24mm)
Height	2.05inches(52mm)
Total Height /w Terminal	2.28inches(58mm)
Weight	Approx 0.66lb(0.30kg)
Standard terminal	Type B

### Capacity Specifications

Cut Off Voltage	20Hr Rate(0.065A)	1.3AH
1.75v/c@25°C	10Hr Rate(0.124A)	1.2AH
1.75v/c	5Hr Rate(0.21A)	1.05AH
1.67v/c	1Hr Rate(0.78A)	0.78AH
1.67v/c	15Min Rate(2.60A)	0.65AH

### Charging Specifications

		Bloc
Charge Voltage( <i>constant</i> )	Float	6.75~6.90
	Cycle	7.25~7.50
Internal Resistance (Fully Charged Battery)	< 50mΩ	
Discharge Current Amps (5 seconds maximum)	19	
Max.Charge Current	0.39A	
Approx Final Charge Current (2.25v/c Float)	0.003(3mA)	
Approx Final Charge Current (2.45v/c Float)	0.01(10mA)	
Self Discharge	6 Months@25°C	

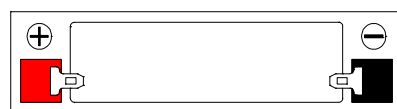

Unit:mm(±0.50)

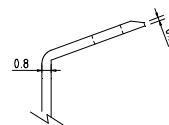
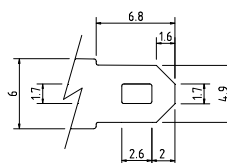
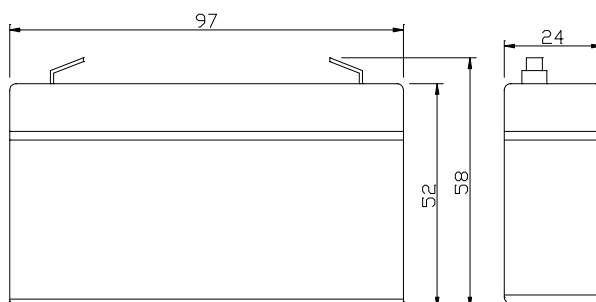

Type B Terminal



### Actual Wattage at Various Discharge (Voltage @25°C )

Cut Off Voltage	Time							
		5min	10min	15min	30min	45min	60min	
4.80V	W	31.2	20.3	15.6	9.0	6.6	5.1	
4.95V	W	30.2	19.9	15.3	8.9	6.6	5.0	
5.10V	W	28.9	19.4	15.0	8.8	6.5	5.0	
5.25V	W	27.2	18.7	14.5	8.6	6.3	4.9	
5.40V	W	23.5	17.3	13.9	8.3	6.0	4.7	

### Sales Office:

9/F, 30 Wong Chuk Hang Road, Aberdeen, Hong Kong

Tel: 2555-1394 ext163 Web: [www.remcobattery.com](http://www.remcobattery.com)

Fax: 2873-4229

Email: [sales@remcobattery.com](mailto:sales@remcobattery.com)